

TIGERGRIP | UNIVERSAL GRAB HEAVY DUTY GX Series - 5

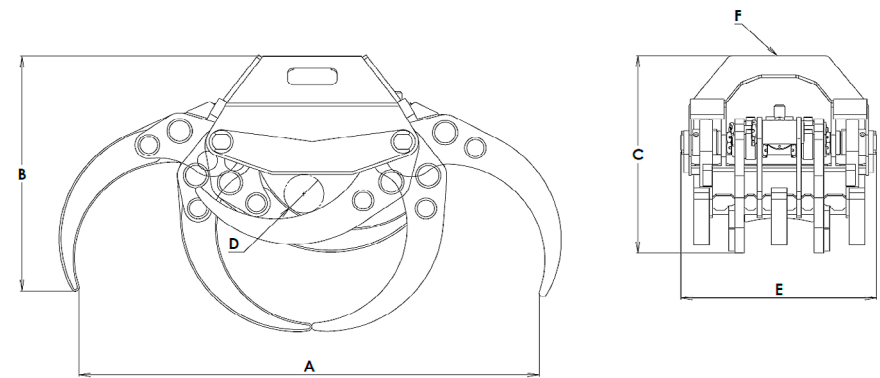

KEY FEATURES

- 5 fingers
- Heavy duty
- Double guide bars
- Optimized roll in/roll out properties
- High pressure cylinder with double piston rod seals
- High tensile wear resistant steel (400 HB)
- Extra reinforced body for rigid mounting - Excavator design



	GX 28-50	GX 36-50	GX 55-50
A	1485	1800	2295
B	783	910	1100
C	658	720	828
D	130	135	145
E	632	658	1010

MODEL SPECIFICATIONS	WEIGHT Kg	GRIP AREA m ²	PRESSURE Bar	FLOW l/min	CLAMPING kN	FORESTRY tm	CAPACITY ton	PENDULUM ton	RIGID ton	FORWARDER
----------------------	--------------	-----------------------------	-----------------	---------------	----------------	----------------	-----------------	-----------------	--------------	-----------

GX 28-50 - 5	495	0.28	350	60	20	30	8	20	14	OK
GX 36-50 - 5	718	0.36	350	60	20.5	40	10	30	24	-
GX 55-50 - 5	1735	0.50	350	70	50	-	12	40	30	-

INTERMERCATO

High performance lift and load attachments for Forestry, Transport, Construction and Recycling.

