



We accept no substitute



TG 16ST
TG 22ST



TG 28SR3

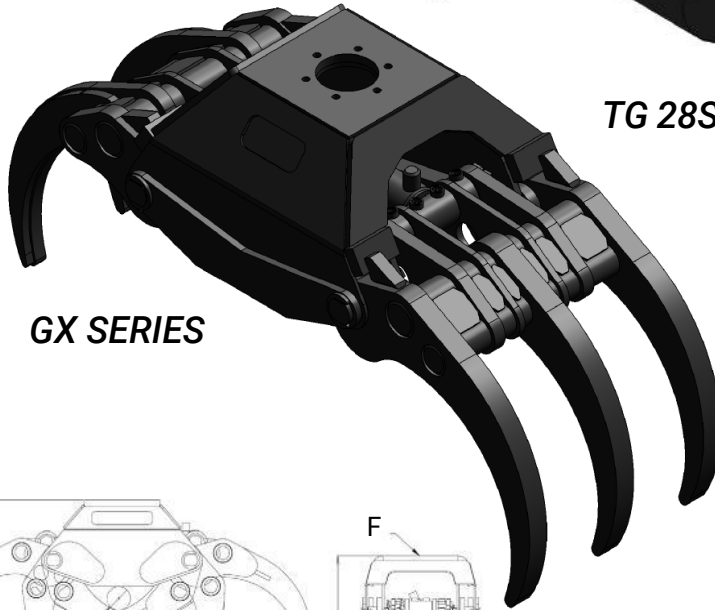

GX SERIES

KEY FEATURES

- Add rotator
- Heavy duty
- Double guide bars
- Spread top pins to reach over the rock for better grip
- High pressure cylinder with double piston rod seals
- HARDOX - high tensile wear resistant steel (400 HB)
- Extra reinforced body for rigid mounting - Excavator design
- 3-5 super heavy duty fingers
- 7 finger available in GX series

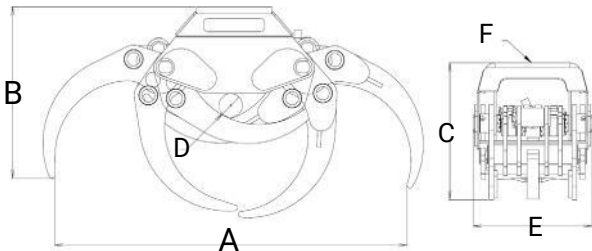

	TG 16 ST	TG 22 ST	TG 25 SR3	TG 28 SR3	GX28 50/5	GX36 50/5	GX55 50/5
A	785	1035	1500	1500	1486	1800	2295
B	520	545	796	730	783	910	1100
C	387	513	520	582	658	720	828
D	55	85	50	100	130	135	145
E	330	350	423	508	632	658	1010

MODEL SPECIFICATIONS	WEIGHT Kg	GRIP AREA m ²	PRESSURE Bar	FLOW l/min	CLAMPING kN	FORESTRY tm	CAPACITY ton	PENDULUM ton	RIGID ton	FORWARDER
TG 16 ST	65	0.16	200	20-40	9	3	1	3	2-3.5	-
TG 22 ST	125	0.22	200	30-50	13.5	4	1.5	4	3-5.5	-
TG 25 SR3	190	0.25	250	50	12.6	8	3	10	6-10	-
TG 28 SR3	300	0.30	250	60	16.6	15	5	15	8-14	OK
GX28-50/5	495	0.28	350	60	20	30	8	20	12-18	OK
GX36-50/5	720	0.36	350	60	20	40	10	30	20-30	-
GX55-50/5	1735	0.50	350	70	50	-	12	40	20-32	-

