

ROTECH / DEMOLITION RIGID MOUNT ROTATORS

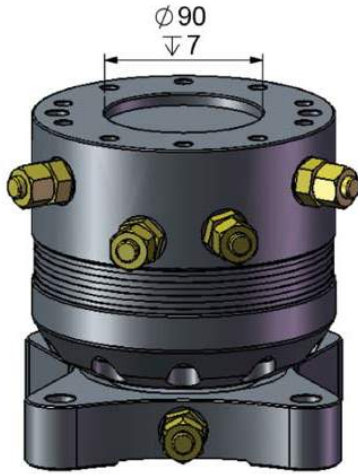

RMR 3

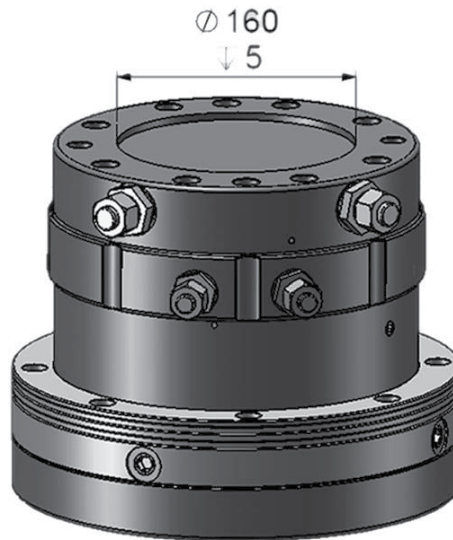

RMR 12

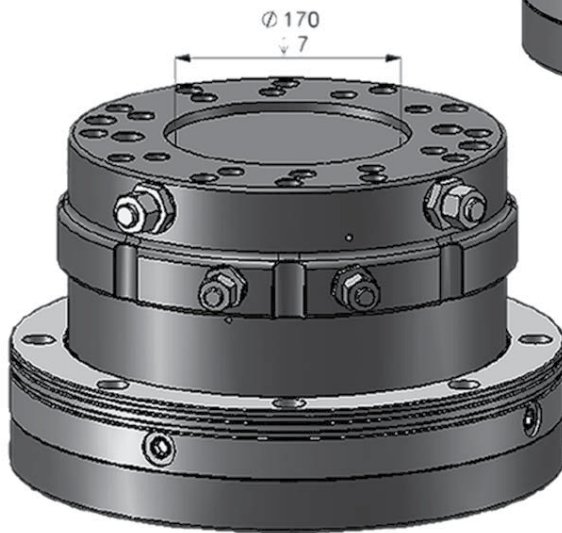

RMR 16C

RMR Series: G-rotor
(not designed to hold vertical items steady)

KEY FEATURES

- Fast operation
- Endless rotation
- High torque
- Steel flange for increased durability
- Ultra compact design
- High pressure construction
- Forged drive shafts & large tapered roller bearings resist high axial & radial loading.

| MODEL SPECIFICATIONS | WEIGHT Kg | STATIC ton | PRESSURE Bar | FLOW l/min | 360° | TORQUE Nm | FITTINGS | PENDULUM ton | RIGID ton | BOTTOM FLANGE PCD | TOP FLANGE PCD | HEIGHT |
|----------------------|--------------|---------------|-----------------|---------------|------|--------------|----------|-----------------|--------------|-------------------|----------------|--------|
| RMR 3 | 30 | 5 | 320 | 22 | 360° | 1300 | M18x1.5 | 10 | 1-3.5 | 140/4 | 144/10 | 188 |
| RMR 6 C | 50 | 7 | 320 | 25 | 360° | 2800 | 1/5" | 14 | 3-5.6 | 173/6 | 185/8 | 205 |
| RMR 12 | 92 | 28 | 320 | 25 | 360° | 3800 | 1/2'3/4" | 25 | 6-12 | 270/8 | 210/10 | 228 |
| RMR 16 C | 164 | 38 | 320 | 25 | 360° | 3800 | 1/2'3/4" | 35 | 12-16 | 340/8 | 265/12 | 229 |